

Meet

DINO 120TB

DINO® TRAILER MOUNTED MEWPs

Standard features in DINO 120TB:

- Lightweight, robust, cost-effective
- Driving system; easy to move at work site
- Large outrigger pads 280 x 360 mm
- Continuous rotation of the boom; easy and functional
- Stable to tow, easy to transport
- Easy and fast setup; perfect solution for short time jobs
- Simple to use, clear and informative controls
- Powerful charger; machine can be operated directly when charging the batteries



Options available for DINO 120TB:

- 2kW Honda generator + bracket for charging batteries where 230VAC is not available
- Cable steering for driving
- Outrigger support indicator
- Extra outrigger pads 500 x 500 x 35 mm + bracket
- Lockable tool / harness box
- Spare wheel

Technical data

	120TB
Max. working height	12.00 m
Max. platform height	10.00 m
Max. outreach	7.90 m
Support width	3.15 / 3.55 m
Lifting capacity	130 kg
Basket size	0.75 x 0.80 m
Boom rotation	cont.
Boom control	2-speed
Transport length	5.56 m
Transport width	1.72 m
Transport height	1.95 m
Weight	1360 kg
Driving system	std
AC socket in the basket x 2	std
Batteries 140 Ah	std
DC Motor	std
Gradeability	25 %

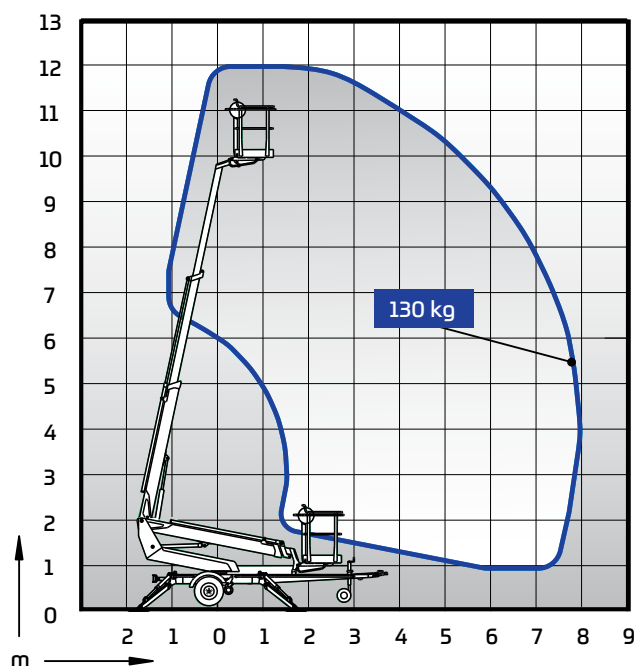

DINOLIFT

UP TO THE JOB

Dinolift Oy | Raikkolantie 145 • FI-32210 LOIMAA, FINLAND

Tel: +358 (0)20 1772 400 • E-mail: info@dinolift.com

www.dinolift.com

Technical specifications are subject to change without prior notice.

©Dinolift Oy | 22.2.2021