

Meet

DINO 135TB II

DINO® TRAILER MOUNTED MEWPs

Standard features in DINO 135TB II

- Lightweight, robust, cost-effective
- Driving system; easy to move at work site
- Spacious, easy-entry basket; capacity 215 kg
- Large outrigger pads 280 x 360 mm
- Continuous rotation of the boom; easy and functional
- Basket rotation 90°
- Proportional controls
- Stable to tow, easy to transport
- Easy and fast setup; perfect solution for short time jobs
- Simple to use, clear and informative controls
- Powerful charger; machine can be operated directly when charging the batteries.
- High-capacity batteries, 4 x 6VDC, 235Ah. Work one day with overnight charge.



Options available for DINO 135TB II

- 2kW Honda generator + bracket for charging batteries where 230VAC is not available
- Cable steering for driving
- Outrigger support indicator
- LED working lights
- DINO SafeGuard secondary guarding
- Extra outrigger pads 500 x 500 x 35 mm + bracket
- Lockable tool / harness box
- Rack for tools and accessories
- Spare wheel

Technical data

	135TB II
Max. working height	13.50 m
Max. platform height	11.50 m
Max. outreach	9.10 m
Support width	3.8 / 4.2 m
Lifting capacity	215 kg
Basket size	0.7 x 1.3 m
Boom rotation	cont.
Basket rotation	90°
Boom control	proport.
Transport length	6.09 m
Transport width	1.79 m
Transport height	2.16 m
Weight	1765 kg
Driving system	std
AC socket in the basket x 2	std
Batteries 235 Ah	std
DC Motor	std
Gradeability	25 %

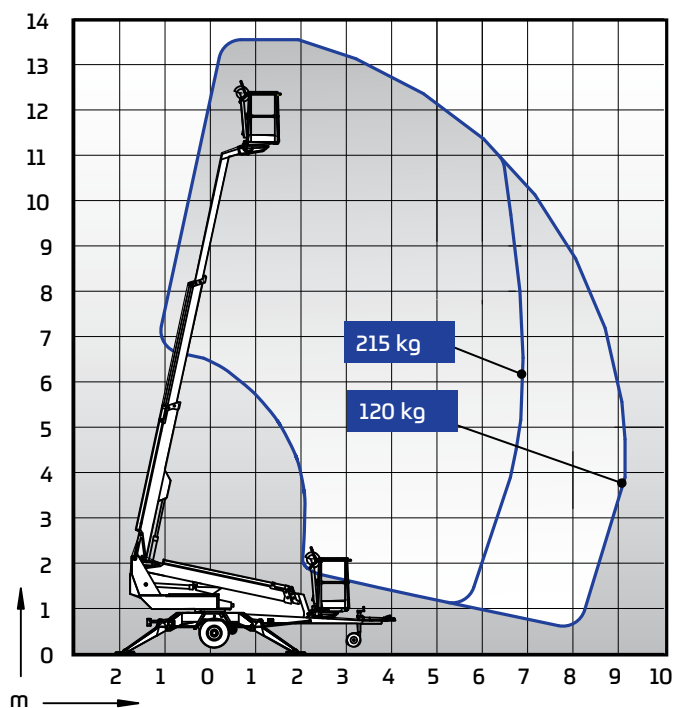

DINOLIFT

UP TO THE JOB

Dinolift Oy | Raikkolantie 145 • FI-32210 LOIMAA, FINLAND

Tel: +358 (0)20 1772 400 • E-mail: info@dinolift.com

www.dinolift.com

Technical specifications are subject to change without prior notice.

©Dinolift Oy | 22.2.2021